

TSP-160: WIRING KIT

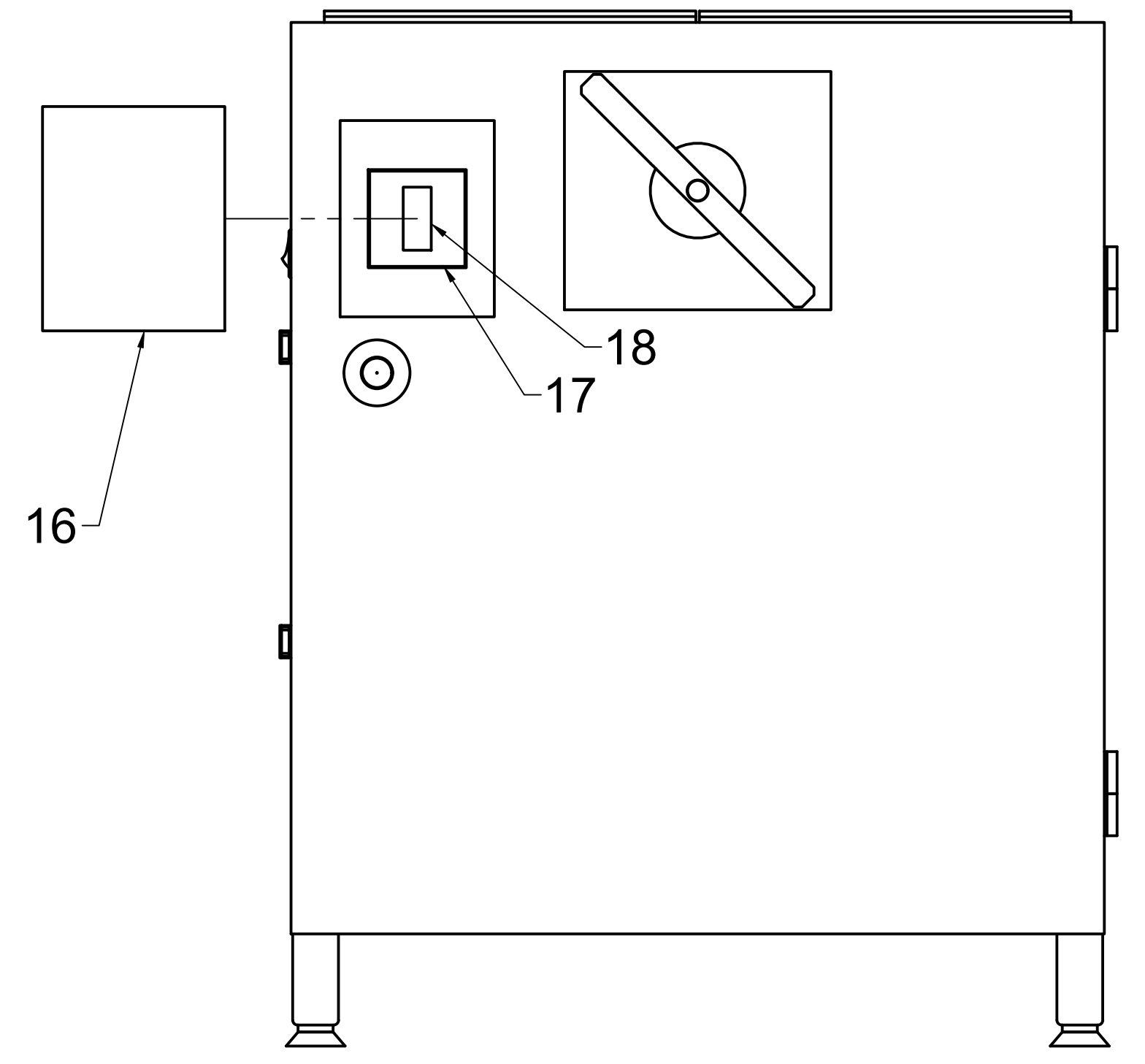

ITEM	QTY	DESCRIPTION
19	1	TERMINAL BLOCK
18	1	JUNCTION BOX
17	1	UTILITY BOX COVER

ITEM	QTY	PART NUMBER	DESCRIPTION
18	1	TSP-155	TCD1 ELEMENT COVER
17	2	TSP-124	SPRING LOADED CATCH & STRIKE
16	4	TSP-110	4" ADJUSTABLE METAL LEG
15	2	TSP-134RF	FEMALE LOADING HINGE PLATE RIGHT
14	2	TSP-134LF	FEMALE LOADING HINGE PLATE LEFT
13	1	TSP-175	JUNCTION BOX W/ TERMINAL BLOCK
11.1	1	TSP-104	THERMOSTAT DIAL
11	1	TSP-103	60-250 DEGREE F THERMOSTAT
10	1	TSP-101	ON/OFF ROCKER SWITCH
9	2	TSP-102	725W FINNED STRIPED HEATER
8.1	2	TSP-134R	MALE LOADING HINGE PLATE LEFT
8	1	TSP-105/TSP-107	TCD1 RIGHT LOADING DOOR WITH HINGE & HANDLE
7	2	TSP-119	TCD1 MAIN DOOR STAINLESS STEEL SLEP HINGES
6	1	TSP-151	TCD1 AIR DUCT
5	1	TSP-109	TCD1 BLOWER WHEEL FAN
4	1	TSP-135TCD	PERFORATED INTERIOR STAINLESS STEEL LINER FOR TCD1
3.2	1	TSP-130	DOOR HANDLE WITH WASHER & MACHINE SCREW
3.1	2	TSP-134L	MALE LOADING HINGE PLATE RIGHT
3	1	TSP-106/TSP-108	TCD1 LEFT LOADING DOOR WITH HINGE & HANDLE
2.1	1	TSP-123	MOTOR SUPPORT BRACKET
2	1	TSP-100	MODEL TCD1 1/40 HP ELECTRIC MOTOR
1.4	1	TSP-114	ACCESS DOOR HINGE RIGHT
1.3	1	TSP-115	ACCESS DOOR HINGE LEFT
1.2	2	TSP-119	TCD1 MAIN DOOR STAINLESS STEEL SLIP HINGES
1.1	1	TSP-152	TCD1 ACCESS DOOR ASSEMBLY
1	1	TSP-170	TCD1 MAIN DOOR ASSEMBLY

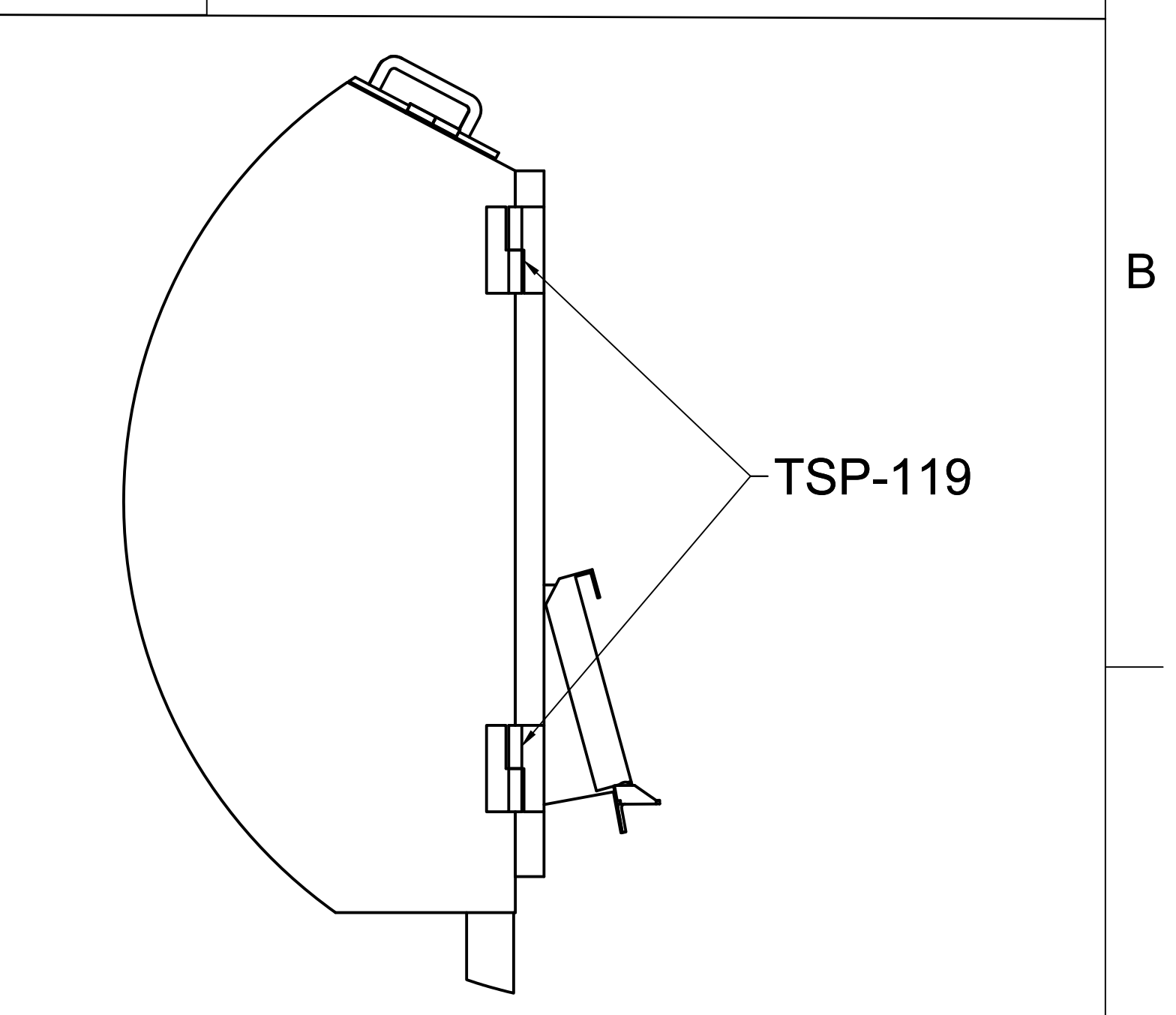

		PROJECT			
		Chip Machines			
		TITLE			
		TCD1			
APPROVED	SIZE	CODE	DWG NO	REV	
CHECKED	D				
DRAWN jon spilger 11/8/24		SCALE 1:4	WEIGHT	SHEET 1/1	

PARTS LIST